

THIS DRAWING IS UNPUBLISHED. RELEASED FOR PUBLICATION ,19 .  
 © COPYRIGHT 19 BY AMP INCORPORATED. ALL RIGHTS RESERVED.

LOC	DIST	REVISIONS			
P	LTR	DESCRIPTION	DATE	DWN	APVD
G	14				
	D	REV / 0L20-0197-97	21AUG97	ME	SB

<b>AMP</b> WIRE RANGE	<b>UL</b> E13288	<b>SP</b> LR7189 Certified
12-10 AWG SOLID OR STRANDED	12-10 AWG SOLID OR STRANDED	12-10 AWG SOLID OR STRANDED

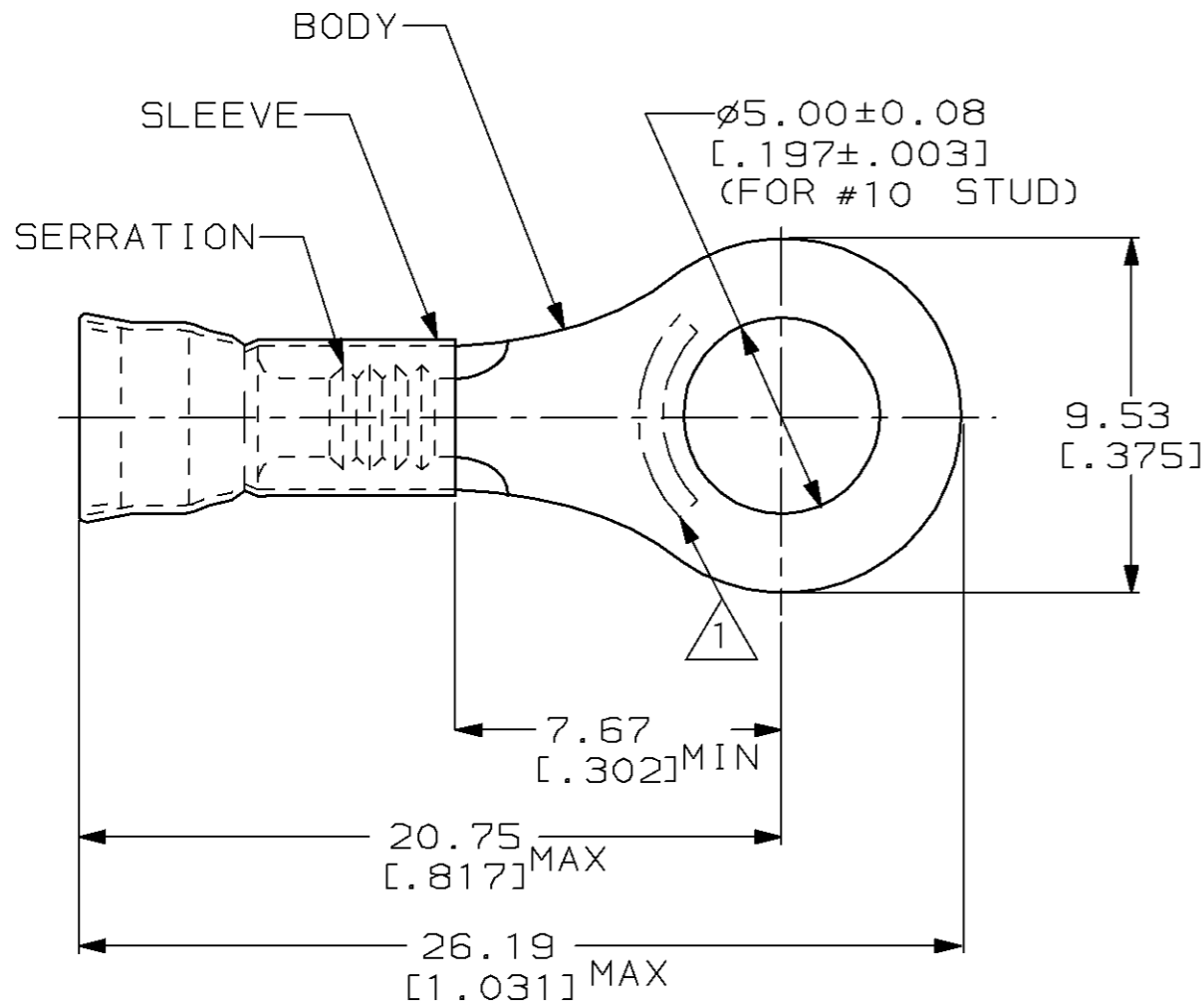

- 1 STAMP AMP 12-10\* LOCATE APPROX AS SHOWN
- 2 WIRE INSUL DIA, 3.81-5.84 [.150-.230]
- 3 TONGUE MATL THK, 0.99±0.05 [.039±.002]

2500	ON TAPE, REEL	2-31771-1
500	LOOSE PIECE	31771
QTY	PACKAGE TYPE	PART NO

AMP INCORPORATED CUSTOMER SERVICE SYSTEM		MAX RECOMMENDED OPERATING TEMPERATURE: 170°C [338°F]	THIS DRAWING IS A CONTROLLED DOCUMENT FOR AMP INCORPORATED. IT IS SUBJECT TO CHANGE AND THE CONTROLLING ENGINEERING ORGANIZATION SHOULD BE CONTACTED FOR THE LATEST REVISION.		DWN L OLMEDA 23JAN95	<b>AMP</b> AMP Incorporated Harrisburg, PA 17105-3608 NAME TERMINAL, RING, DIAMOND GRIP™, WIRE SIZE, 12-10 AWG
FOR ADDITIONAL PRODUCT INFORMATION OR COPIES OF DRAWINGS AND TECHNICAL DOCUMENTS	PRODUCT INFORMATION CENTER 1-800-522-6752	VOLTAGE RATING: -	DIMENSIONS: mm [in]	TOLERANCES UNLESS OTHERWISE SPECIFIED:	CHK M ELLIS 23JAN95	
FOR APPLICATION TOOLING INFORMATION	TOOLING ASSISTANCE CENTER 1-800-722-1111	CIRCULAR MIL AREA: 2.62mm²-6.64mm² [5180-13100]		0 PLC ±- 1 PLC ±- 2 PLC ±0.20 [.008] 3 PLC ±- 4 PLC ±- ANGLES ±-	APVD S BORTNER 23JAN95	
FOR ORDER ENTRY	1-800-526-5142	MATERIAL BODY, CU, SLV, CU PER ASTM B152	FINISH TIN PLATE PER ASTM B 545	PRODUCT SPEC UL486A	APPLICATION SPEC -	
			CUSTOMER DRAWING		WEIGHT -	SIZE A3
					CAGE CODE 00779	DRAWING NO C-31771
					SCALE 6:1	SHEET 1 OF 1
					REV D	